

42



HB TYPE

附煞車
BRAKE TYPE

1.8°

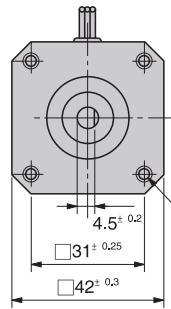
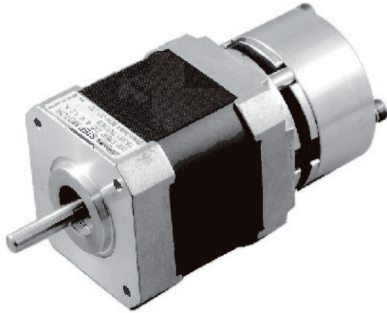

4-M3 深 4.5Min
DEPTH

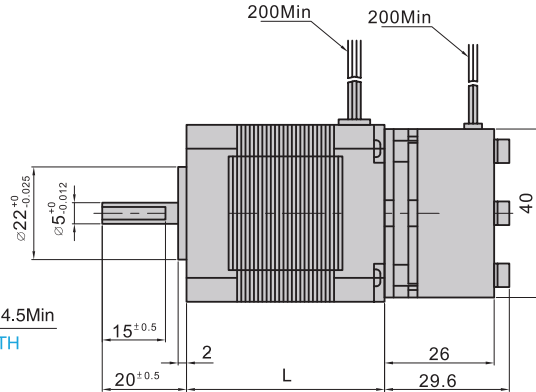

形式 Type number	額定電壓 Rated Voltage V/Phase	額定電流 Rated Current A/Phase	線圈阻抗 Winding Resistance Ω/Phase	激磁最大 靜止力矩 Holding Torque N-m(kgf·cm)	馬達長度L Motor Length mm	轉子慣量 Rotor Inertia g·cm ²	質量 Mass g
K243-01M	4.0	0.95	4.2	0.16(1.6)	33	35	370
K244-01M	4.0	1.2	3.3	0.26(2.6)	39	54	410
K245-01M	4.0	1.2	3.3	0.32(3.2)	47	68	480

- 使用周圍溫度 ———— -20~+50 °C
Operating temperature range
- 絕緣阻抗 ———— 100MΩ Min(at DC500V)
Insulation resistance
- 絕緣耐壓 ———— AC500V(1min)
Dielectric strength
- 軸心平行方向移動量 — 0.075mm Max.at the load 9.8N(1kgf)
End play
- 軸心垂直方向移動量 — 0.025mm Max.at the load 4.9N(0.5kgf)
Radial play
- 容許溫度上昇 ———— 80deg Max(Rasistance method)
Permissible temperature rise

煞車規格

- 動作原理: 斷電煞車(無激磁煞車)
- 額定電壓: DC24V
- 入力容量: 4.5W
- 線圈電流: 0.175A
- 線圈阻抗: 137Ω
- 靜摩擦扭力: 2kg.cm

※ 注意: 馬達表面請保持在90 °C以下

※ NOTE: Do not allow the surface temperature of the motor case to rise above 90 °C during operation.